

ENERGIZER 675 size - **Mercury Free**

ZnAir

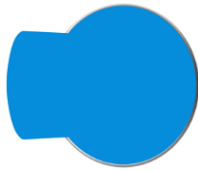

Industry Standard Dimensions

mm (inches)

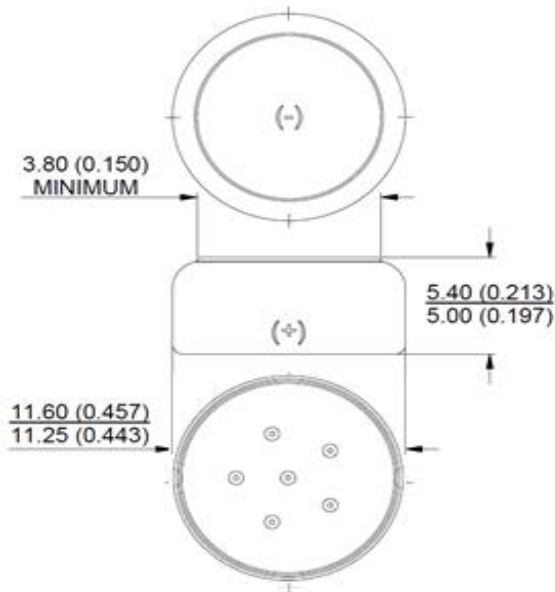

General Information

Chemical System:	Zinc Air (Zn/O ₂)
Tab Color:	Blue
Designation:	ANSI-7003ZD, IEC-PR44
Nominal Voltage:	1.4 Volts
Typical Capacity:	529 mAh (to 1.05 volts) (IEC-STD at 15/5 mA at 21°C)
Typical Weight:	1.9 grams (0.1 oz.)
Typical Volume:	0.5 cubic centimeters (0.03 cubic inch)

Typical Discharge Characteristics

IEC Industry Standards / Standard Test Protocol
(15/5 mA .1S/1H59M 59.9S 12H at 21C)

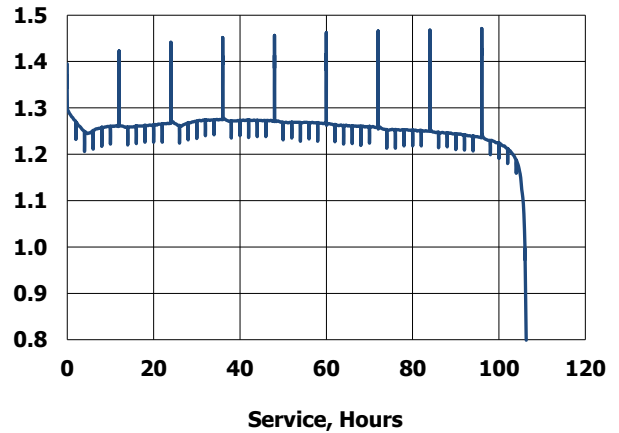

Typical Discharge Characteristics

IEC Industry Standards / High Drain Test Protocol
(24/8 mA .1S/1H59M 59.9S 12H at 21C)

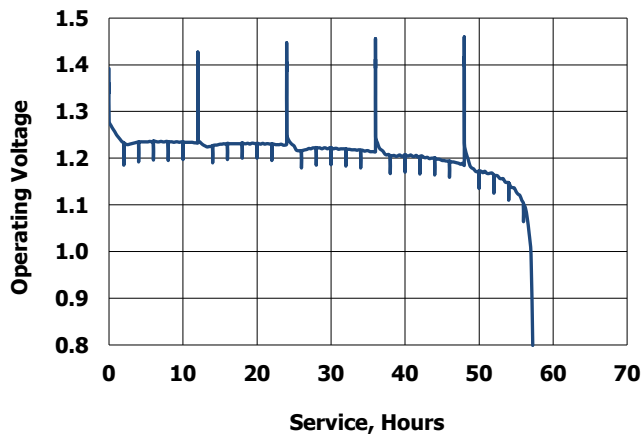

Important Notice

This datasheet contains typical information specific to products manufactured at the time of its publication.
Contents herein do not constitute a warranty and are for reference only.