



<https://www.mega-piles.com/>

ENERGIZER NH15-2300 (HR6)

AA



Specifications

Classification:	Rechargeable
Chemical System:	Nickel-Metal Hydride (NiMH)
Designation:	ANSI-1.2H2 IEC-HR6
Nominal Voltage:	1.2 Volts
Rated Capacity:	2300 mAh at 21°C (70°F) Based on 460 mA (0.2C) discharge rate
Typical Weight:	28 grams (0.99 oz.)
Typical Volume:	8.3 cubic centimeters (0.5 cubic inch)
Terminals:	Flat Contact
Jacket:	Plastic

Industry Standard Dimensions

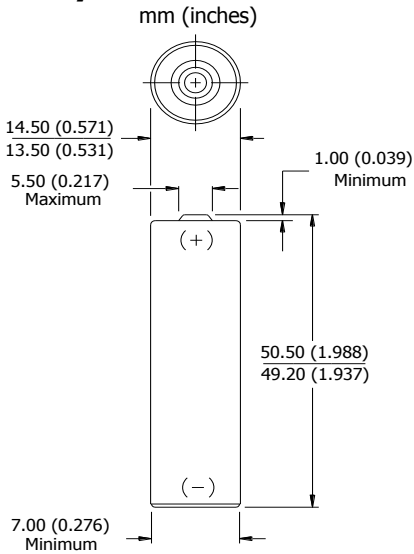

Internal Resistance:

The internal resistance of the cell varies with state of charge, as follows:

<u>Cell Charged</u>	<u>Cell 1/2 Discharged</u>
30 milliohms	40 milliohms
(tolerance of ±20% applies to above values)	

AC Impedance (no load):

The impedance of the charged cell varies with frequency, as follows:

<u>Frequency (Hz)</u>	<u>Impedance (milliohms)</u> (charged cell)
1000	12

Above values based on AC current set at 1.0 ampere.
Value tolerances are ±20%.

Discharge Characteristics

Typical Performance at 21°C (70°F)

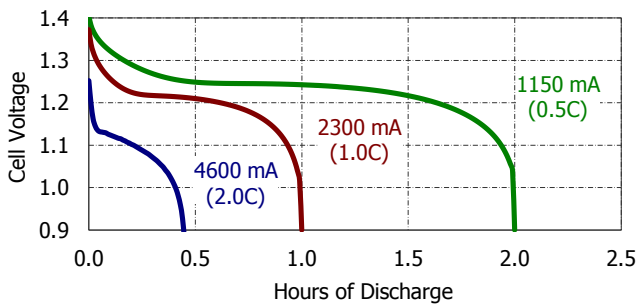
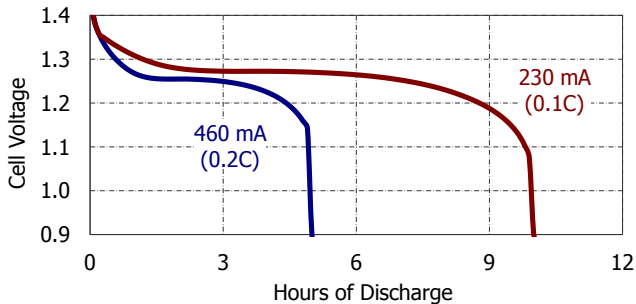

Operating and Storage Temperatures:

To maintain maximum performance, observe the following general guidelines regarding environmental conditions:

Charge:	0°C to 40°C (32°F to 104°F)
Discharge:	0°C to 50°C (32°F to 122°F)
Storage:	-20°C to 30°C (-4°F to 86°F)
Humidity:	65±20%

NOTE: Operating at extreme temperatures, will significantly impact battery cycle life.

Important Notice

This data sheet contains typical information specific to products manufactured at the time of its publication.
Contents herein do not constitute a warranty and are for reference only.