

**ENERGIZER 397/396**

**ZEROMERCURY**

**SILVER OXIDE**



**Industry Standard Dimensions**

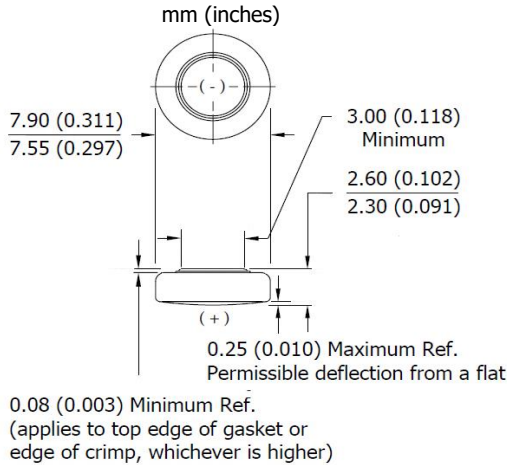

DESIGNED FOR USE ON CONTINUOUS LOW DRAIN  
HIGH PULSE ON DEMAND

**Specifications**

<b>Chemical System:</b>	Silver Oxide (Zn/Ag <sub>2</sub> O)
<b>Designation:</b>	ANSI-1164SO/1163SO, IEC-SR59
<b>Nominal Voltage:</b>	1.55 Volts
<b>Typical Capacity:</b>	31 mAh* (to 1.2 volts)
<b>Capacity Test:</b>	33K ohm continuous drain at 21°C
<b>Typical Weight:</b>	0.5 grams (0.018 oz.)
<b>Typical Volume:</b>	0.13 cubic centimeters (0.008 cubic inch)
<b>Impedance (40 Hz):</b>	15 to 30 ohms

\* Varies according to the applied load, temperature, and cutoff voltage.

**Cross Section**

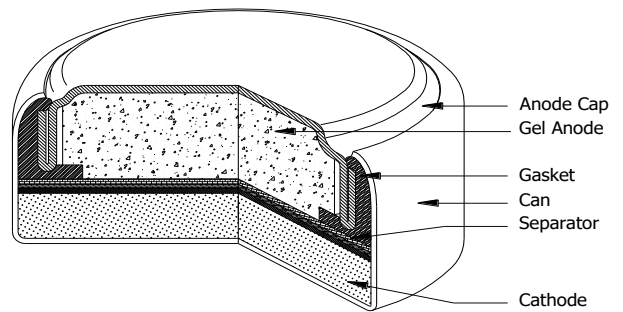

**Typical Discharge Characteristics**

Typical Performance at 21°C (70°F)

**Schedule:** Continuous  
**Typical Drain @1.49V:**  
0.045 milliamperes  
**Load:** 33K ohm

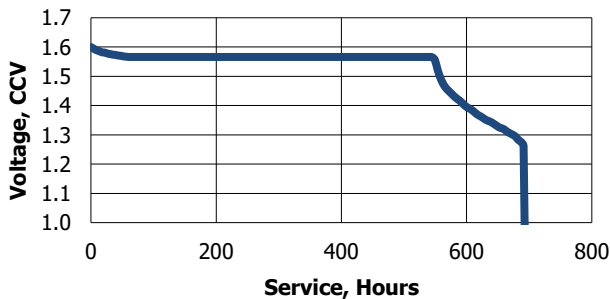

<b>Schedule</b>	<b>Typical Drains at 1.49V (milliamperes)</b>	<b>Load (ohm)</b>	<b>Cutoff (hours)</b>
Continuous	0.045	33K	687

**Temperature Characteristics**

Typical Performance at Low Discharge Rates

**Service Effects**

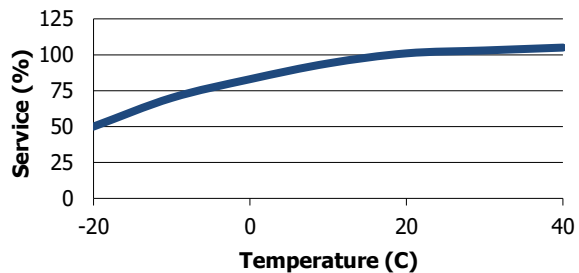

**Storage Effects**

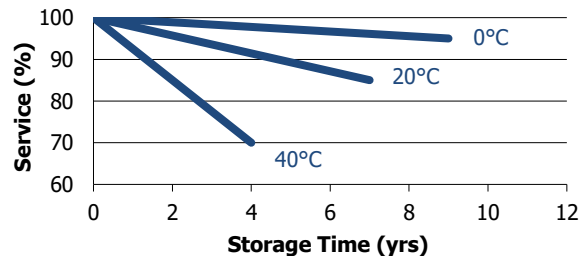

**Important Notice**

This datasheet contains typical information specific to products manufactured at the time of its publication.  
**Contents herein do not constitute a warranty and are for reference only.**