

DURACELL®

Size: 312

Zinc Air Battery – 0% Mercury

Zn/O₂

MEGA-PILES

<https://www.mega-piles.com/>

	
Nominal Voltage	1.45 V
Rated Capacity	185 mAh at 1500 ohm to 1.1 V @ 21°C and 50% RH
Typical Impedance (Fresh)	5.5 ohm @ 1kHz
Typical Weight	0.58 g (0.020 oz)
Volume	0.18 cm ³ (0.011 in ³)
Terminals	Flat
Operating Temperature Range	0°C to 50°C (32°F to 122°F)
Recommended Storage Temperature	5°C to 30°C with 40-80% RH
Shelf Life	4 years unactivated @ 21°C
Designation	ANSI: 7002Z IEC: PR41

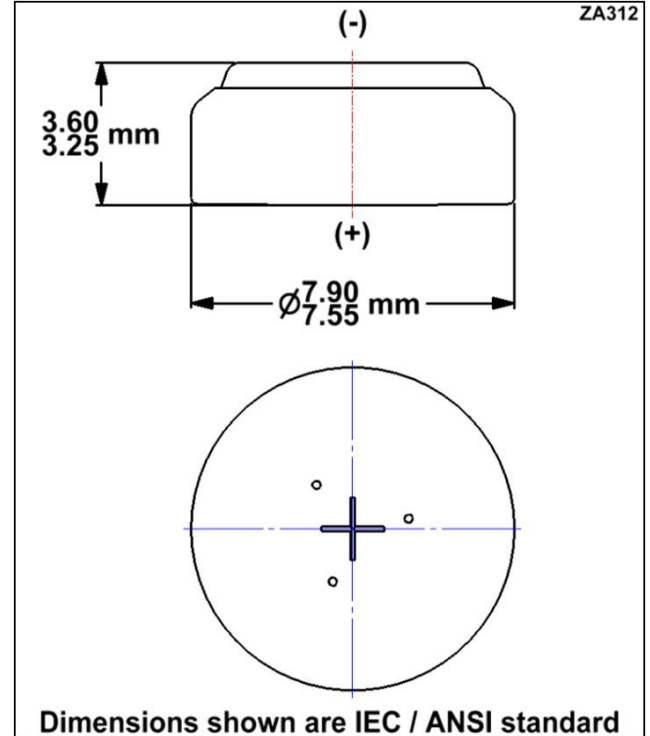

Typical Discharge Characteristics at 21°C (70°F) and 50% RH

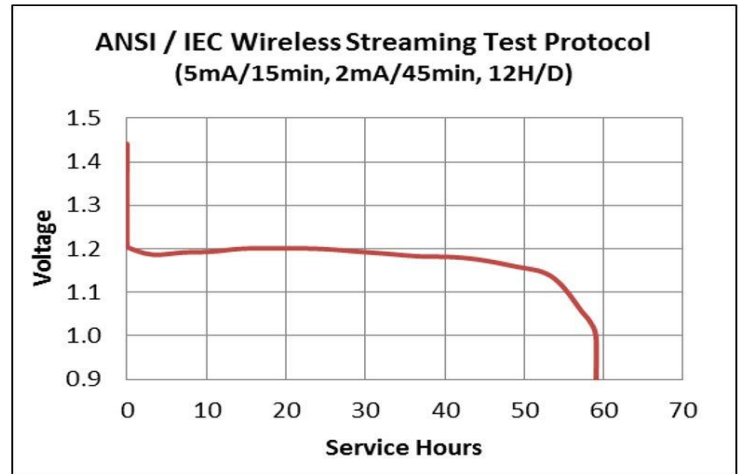
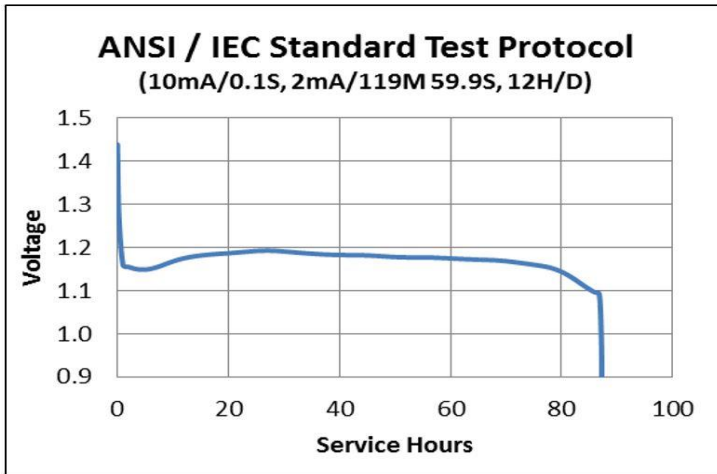

DURACELL®

BATTERIES

Berkshire Corporate Park
Bethel, CT. 06801 U.S.A.
Telephone: Toll-free 1-800-544-5454
www.duracell.com

Delivered capacity is dependent on the applied load, operating temperature and cut-off voltage. Please refer to the charts and discharge data shown for examples of the energy/service life that the battery will provide for various load conditions.