

ENERGIZER E90

N



Specifications

Classification:	Alkaline
Chemical System:	Zinc-Manganese Dioxide (Zn/MnO ₂) No added mercury or cadmium
Designation:	ANSI-910A, IEC-LR1
Nominal Voltage:	1.5 volts
Nominal IR:	150 to 300 milliohms (fresh)
Operating Temp:	-18°C to 55°C (0°F to 130°F)
Typical Weight:	9.0 grams (0.3 oz.)
Typical Volume:	3.3 cubic centimeters (0.2 cubic inch)
Jacket:	Plastic Label
Terminal:	Flat Contact
Shelf life	5 years

Typical Dimensions

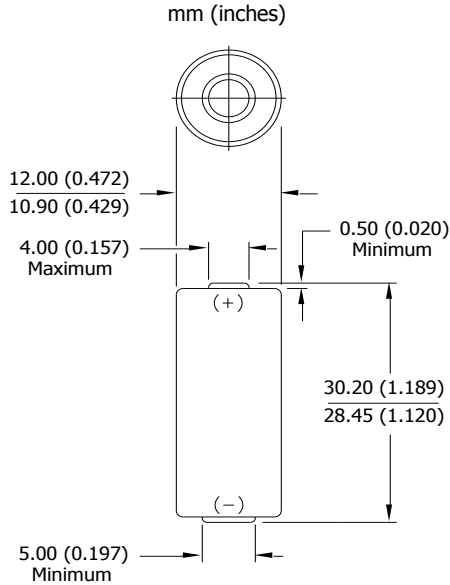

Milliamp-Hours Capacity

Continuous discharge to 0.8 volts at 21°C

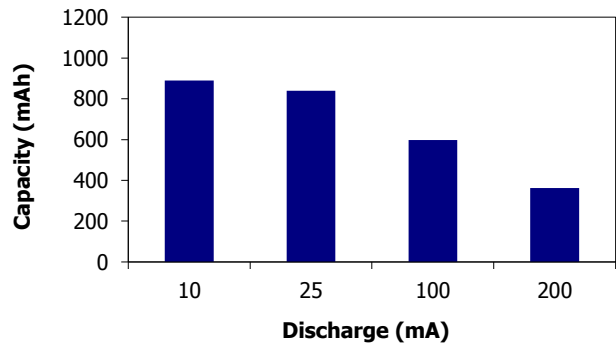

Industry Standard Tests (21°C)

LIGHTING
5.1 ohm 5 min/day

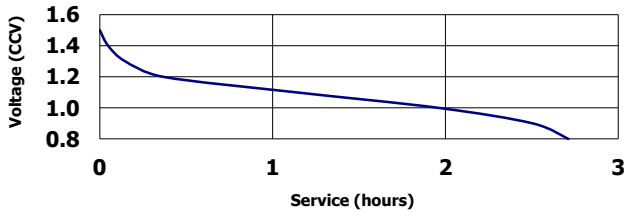

PAGER
3K/10 ohm 5 sec/hr 24 PPD/1 RPD



Important Notice

This data sheet contains typical information specific to products manufactured at the time of its publication.
Contents herein do not constitute a warranty and are for reference only.